

1st STEP: ROUGHING OUT CYLINDERS 1, 2, & 3

M.I.D. KIT #800-850 REF/BORE CENTER 110mm/4.331

REVISIONS

REV	DESCRIPTION	DATE	APPROVAL

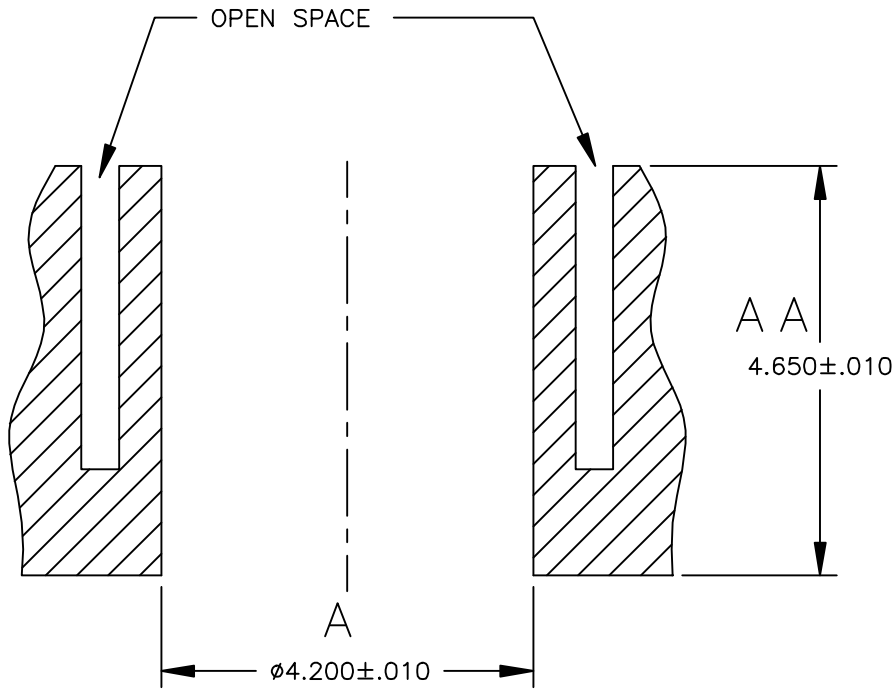

THE INFORMATION DEPICTED HEREIN IS PROPRIETARY DESIGN INFORMATION WHICH IS COPYRIGHTED BY DARTON INTERNATIONAL, INC. NO DUPLICATION OR USE OF THIS INFORMATION IS PERMITTED WITHOUT EXPRESS WRITTEN CONSENT OF DARTON INTERNATIONAL, INC.

DR. BY: CAD DEPT	 Darton International, Inc. Carlsbad, CA USA (800) 713-2786 (760) 603-9895 FAX (760) 603-9629 WWW.DARTON-INTERNATIONAL.COM
DATE: 7/26/2012	
CHK'D BY:	TITLE: BLOCK SPECIFICATION- 3 CYLINDER ROTAX
MATERIAL:	SIZE: A
HARDNESS:	DWG NO. CYLINDERS 1 THRU 3
	SCALE: 1/2
	SHEET 1 of 8

2nd STEP: FINISHING CYLINDERS 1, 2, & 3

M.I.D. KIT #800-850 REF/BORE CENTER 110mm/4.331

REVISIONS			
REV	DESCRIPTION	DATE	APPROVAL

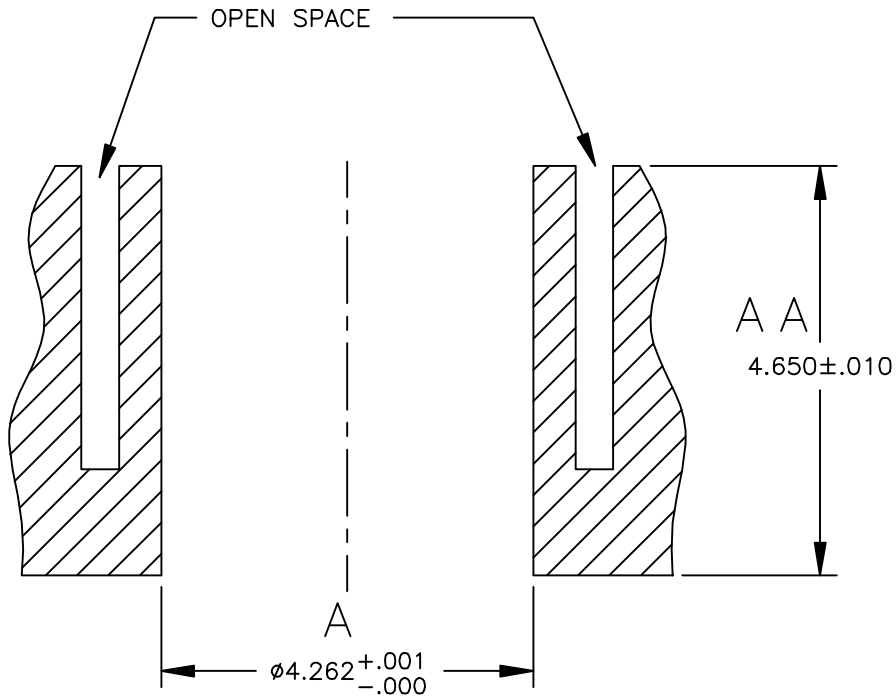

THE INFORMATION DEPICTED HEREIN IS PROPRIETARY DESIGN INFORMATION WHICH IS COPYRIGHTED BY DARTON INTERNATIONAL, INC. NO DUPLICATION OR USE OF THIS INFORMATION IS PERMITTED WITHOUT EXPRESS WRITTEN CONSENT OF DARTON INTERNATIONAL, INC.

DR. BY: CAD DEPT	 Darton International, Inc. Carlsbad, CA USA (800) 713-2786 (760) 603-9895 FAX (760) 603-9629 WWW.DARTON-INTERNATIONAL.COM
DATE: 7/26/2012	
CHK'D BY:	TITLE: BLOCK SPECIFICATION- 3 CYLINDER ROTAX
MATERIAL:	SIZE: A
HARDNESS:	DWG NO. CYLINDERS 1 THRU 3
	SCALE: 1/2
	SHEET 2 THRU 8

3rd STEP: ROUGHING OUT CYLINDERS 2, & 3

M.I.D. KIT #800-850 REF

REVISIONS			
REV	DESCRIPTION	DATE	APPROVAL

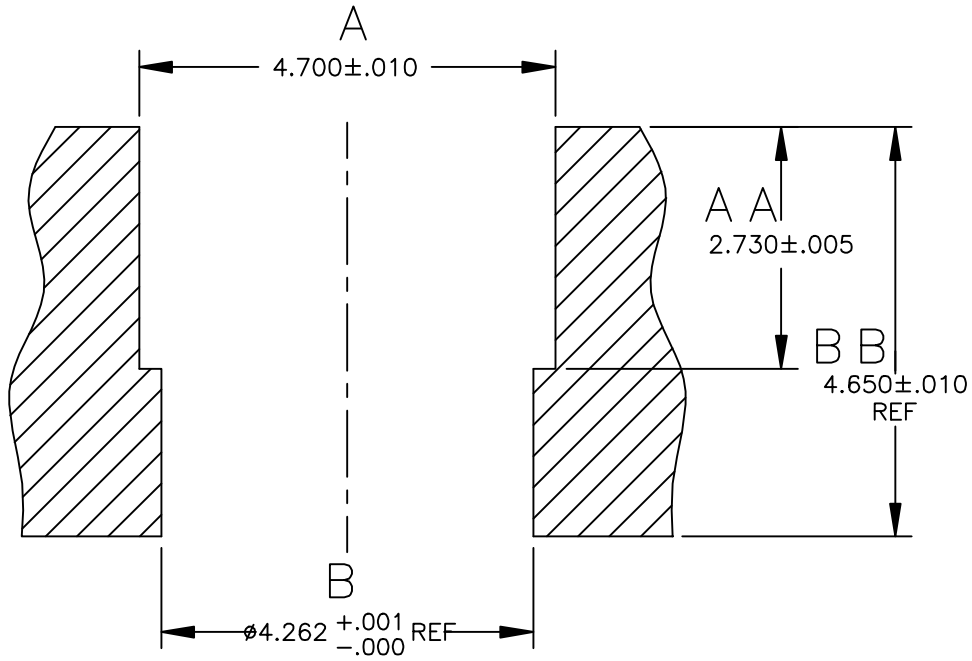

THE INFORMATION DEPICTED HEREIN IS PROPRIETARY DESIGN INFORMATION WHICH IS COPYRIGHTED BY DARTON INTERNATIONAL, INC. NO DUPLICATION OR USE OF THIS INFORMATION IS PERMITTED WITHOUT EXPRESS WRITTEN CONSENT OF DARTON INTERNATIONAL, INC.

DR. BY: CAD DEPT	 Darton International, Inc. Carlsbad, CA USA (800) 713-2786 (760) 603-9895 FAX (760) 603-9629 WWW.DARTON-INTERNATIONAL.COM
DATE: 7/26/2012	
CHK'D BY:	TITLE: BLOCK SPECIFICATION- 3 CYLINDER ROTAX
MATERIAL:	SIZE: A
HARDNESS:	DWG NO. CYLINDERS 2, & 3
	SCALE: 1/2
	SHEET: 3 of 8
	REV: -

4TH STEP: ROUGHING OUT CYLINDER 1

M.I.D. KIT #800-850 REF

REVISIONS			
REV	DESCRIPTION	DATE	APPROVAL

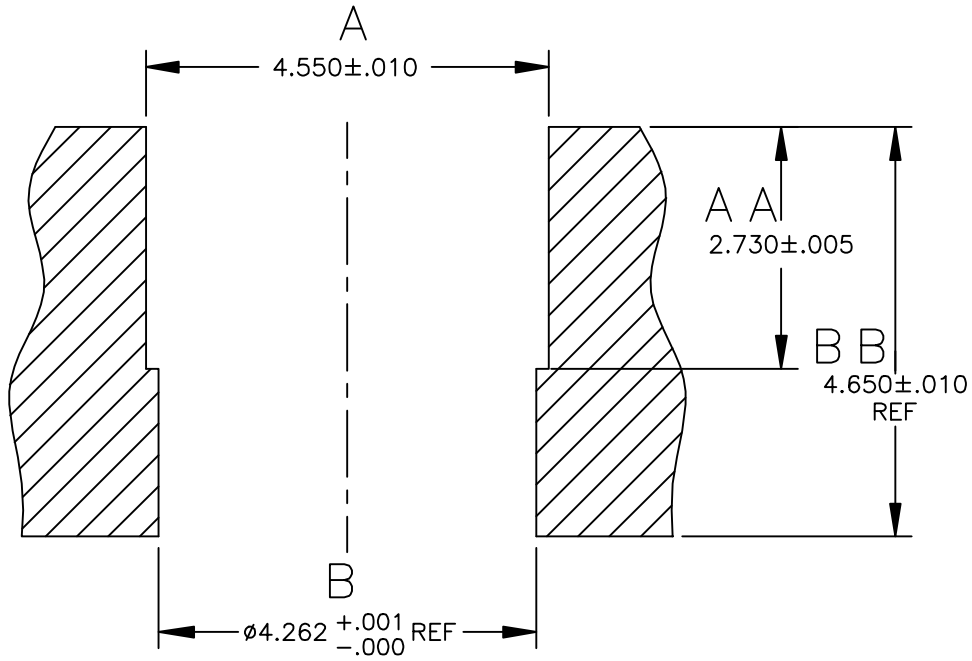

THE INFORMATION DEPICTED HEREIN IS PROPRIETARY DESIGN INFORMATION WHICH IS COPYRIGHTED BY DARTON INTERNATIONAL, INC. NO DUPLICATION OR USE OF THIS INFORMATION IS PERMITTED WITHOUT EXPRESS WRITTEN CONSENT OF DARTON INTERNATIONAL, INC.

DR. BY: CAD DEPT	 Darton International, Inc. Carlsbad, CA USA (800) 713-2786 (760) 603-9895 FAX (760) 603-9629 WWW.DARTON-INTERNATIONAL.COM
DATE: 7/26/2012	
CHK'D BY:	TITLE: BLOCK SPECIFICATION- 3 CYLINDER ROTAX
MATERIAL:	SIZE: A
HARDNESS:	DWG NO. CYLINDER 1
	SCALE: 1/2
	SHEET: 4 of 8

5th STEP: INTERPOLATE SLEEVE SEAT CYLINDERS 1

REVISIONS			
REV	DESCRIPTION	DATE	APPROVAL

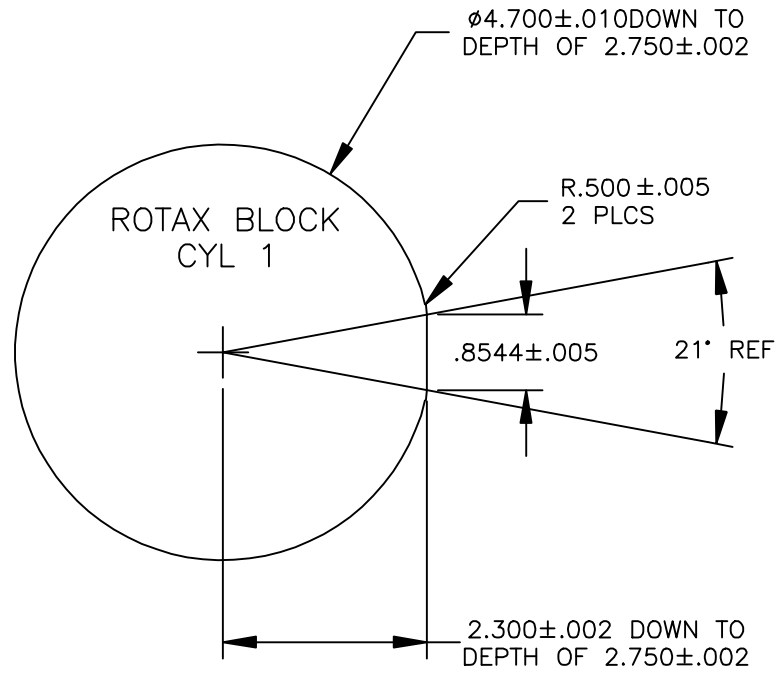

THE INFORMATION DEPICTED HEREIN IS PROPRIETARY DESIGN INFORMATION WHICH IS COPYRIGHTED BY DARTON INTERNATIONAL, INC. NO DUPLICATION OR USE OF THIS INFORMATION IS PERMITTED WITHOUT EXPRESS WRITTEN CONSENT OF DARTON INTERNATIONAL, INC.

DR. BY: CAD DEPT	 Darton International, Inc. Carlsbad, CA USA (800) 713-2786 (760) 603-9895 FAX (760) 603-9629 WWW.DARTON-INTERNATIONAL.COM
DATE: 7/26/2012	
CHK'D BY:	TITLE: BLOCK SPECIFICATION- 3 CYLINDER ROTAX
MATERIAL:	SIZE: A
HARDNESS:	DWG NO. CYLINDER 1
	SCALE: 1/2
	SHEET 5 of 8

6th STEP: INTERPOLATE SLEEVE CYLINDERS 2 & 3

REVISIONS			
REV	DESCRIPTION	DATE	APPROVAL

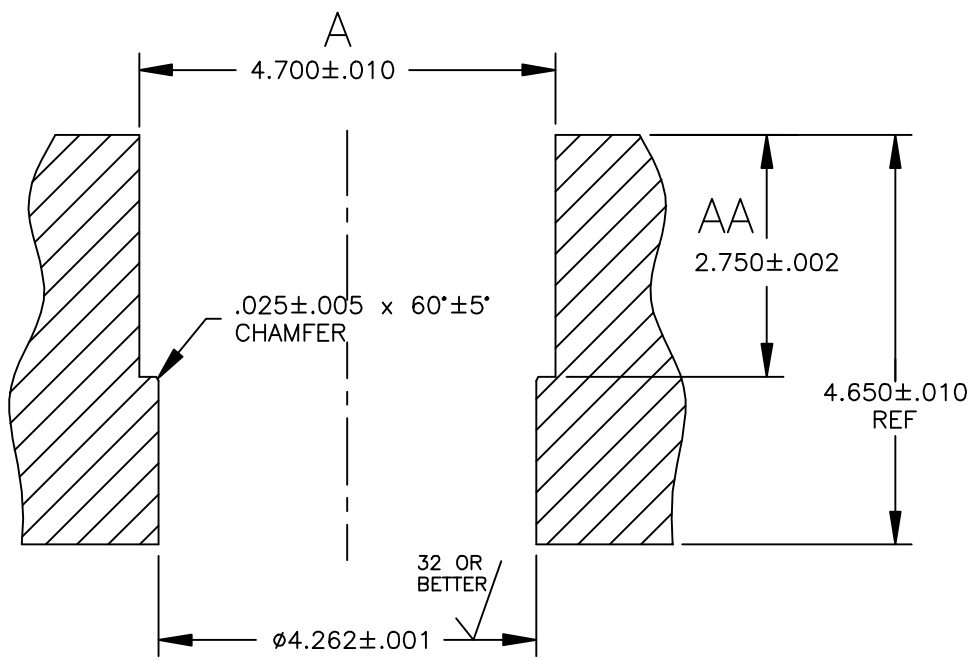

THE INFORMATION DEPICTED HEREIN IS PROPRIETARY DESIGN INFORMATION WHICH IS COPYRIGHTED BY DARTON INTERNATIONAL, INC. NO DUPLICATION OR USE OF THIS INFORMATION IS PERMITTED WITHOUT EXPRESS WRITTEN CONSENT OF DARTON INTERNATIONAL, INC.

DR. BY: CAD DEPT	 Darton International, Inc. Carlsbad, CA USA (800) 713-2786 (760) 603-9895 FAX (760) 603-9629 WWW.DARTON-INTERNATIONAL.COM
DATE: 7/26/2012	
CHK'D BY:	TITLE: BLOCK SPECIFICATION - 3 CYLINDER ROTAX
MATERIAL:	SIZE: A
HARDNESS:	DWG NO. CYLINDERS 2 & 3
	SCALE: 1/2
	REV: -
	SHEET: 6 of 8

7th STEP: INTERPOLATE FLANGE CYLINDER 1

ROTAX CYLINDER 1 SLEEVE DOWN TO DEPTH OF $.450 \pm .010$

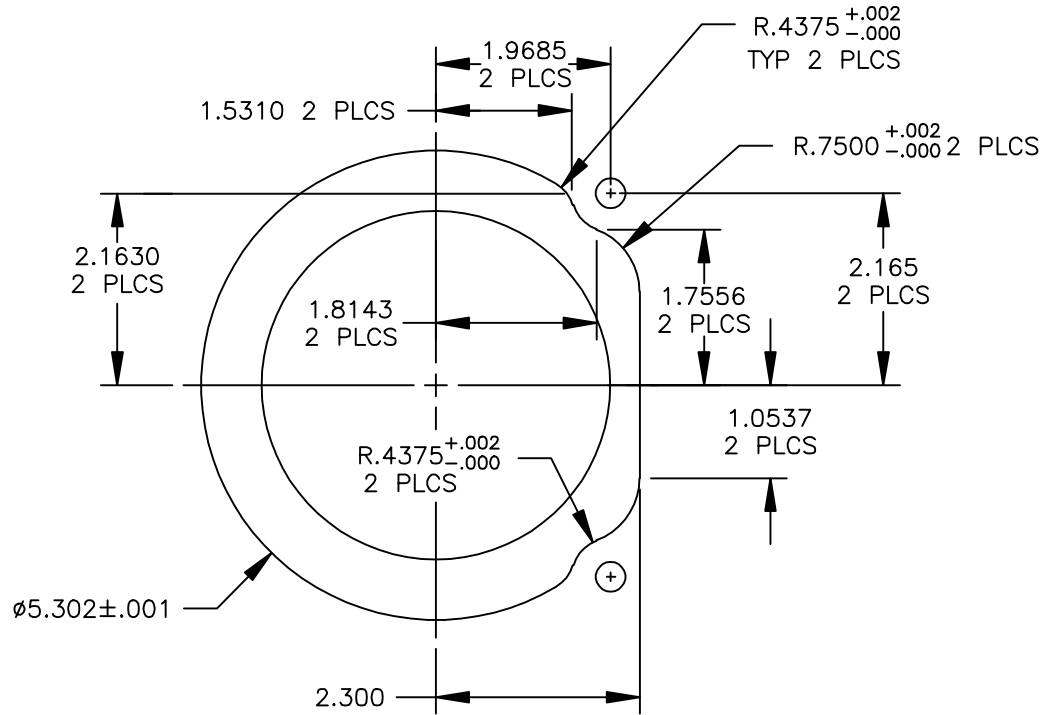

REVISIONS

REV	DESCRIPTION	DATE	APPROVAL

THE INFORMATION DEPICTED HEREIN IS PROPRIETARY DESIGN INFORMATION WHICH IS COPYRIGHTED BY DARTON INTERNATIONAL, INC. NO DUPLICATION OR USE OF THIS INFORMATION IS PERMITTED WITHOUT EXPRESS WRITTEN CONSENT OF DARTON INTERNATIONAL, INC.

DR. BY: CAD DEPT	 Darton International, Inc. Carlsbad, CA USA (800) 713-2786 (760) 603-9895 FAX (760) 603-9629 WWW.DARTON-INTERNATIONAL.COM
DATE: 7/26/2012	
CHK'D BY:	TITLE: BLOCK SPECIFICATION- 3 CYLINDER ROTAX
MATERIAL:	SIZE: A
HANDNESS:	DWG NO. CYLINDER 1
	SCALE: 1/2
	REV: -
	SHEET 7 of 8

8th STEP: FINISHING CYLINDERS 2&3

REVISIONS			
REV	DESCRIPTION	DATE	APPROVAL

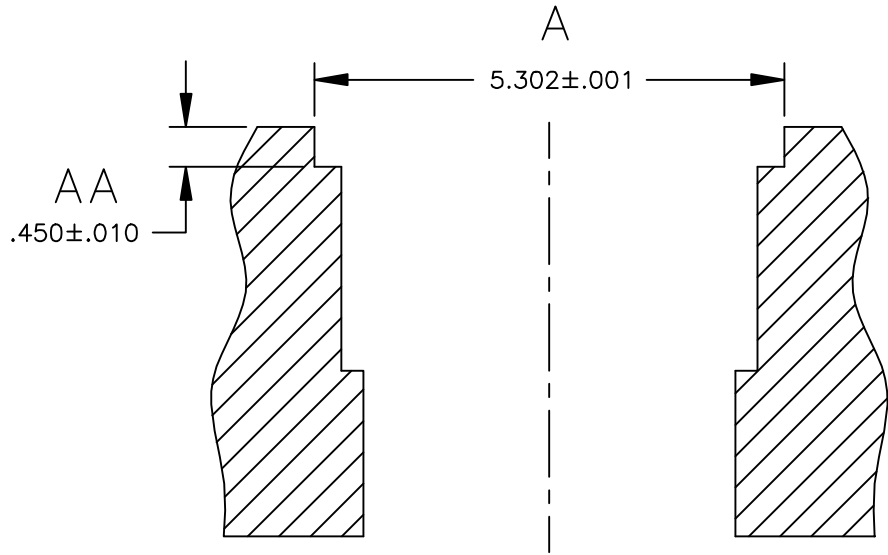

THE INFORMATION DEPICTED HEREIN IS PROPRIETARY DESIGN INFORMATION WHICH IS COPYRIGHTED BY DARTON INTERNATIONAL, INC. NO DUPLICATION OR USE OF THIS INFORMATION IS PERMITTED WITHOUT EXPRESS WRITTEN CONSENT OF DARTON INTERNATIONAL, INC.

DR. BY: CAD DEPT	 Darton International, Inc. Carlsbad, CA USA (800) 713-2786 (760) 603-9895 FAX (760) 603-9629 WWW.DARTON-INTERNATIONAL.COM
DATE: 7/26/2012	
CHK'D BY:	TITLE: BLOCK SPECIFICATION- 3 CYLINDER ROTAX
MATERIAL:	SIZE: A
HANDNESS:	DWG. NO.: CYLINDERS 2, & 3
	SCALE: 1/2
	SHEET: 8 of 8