

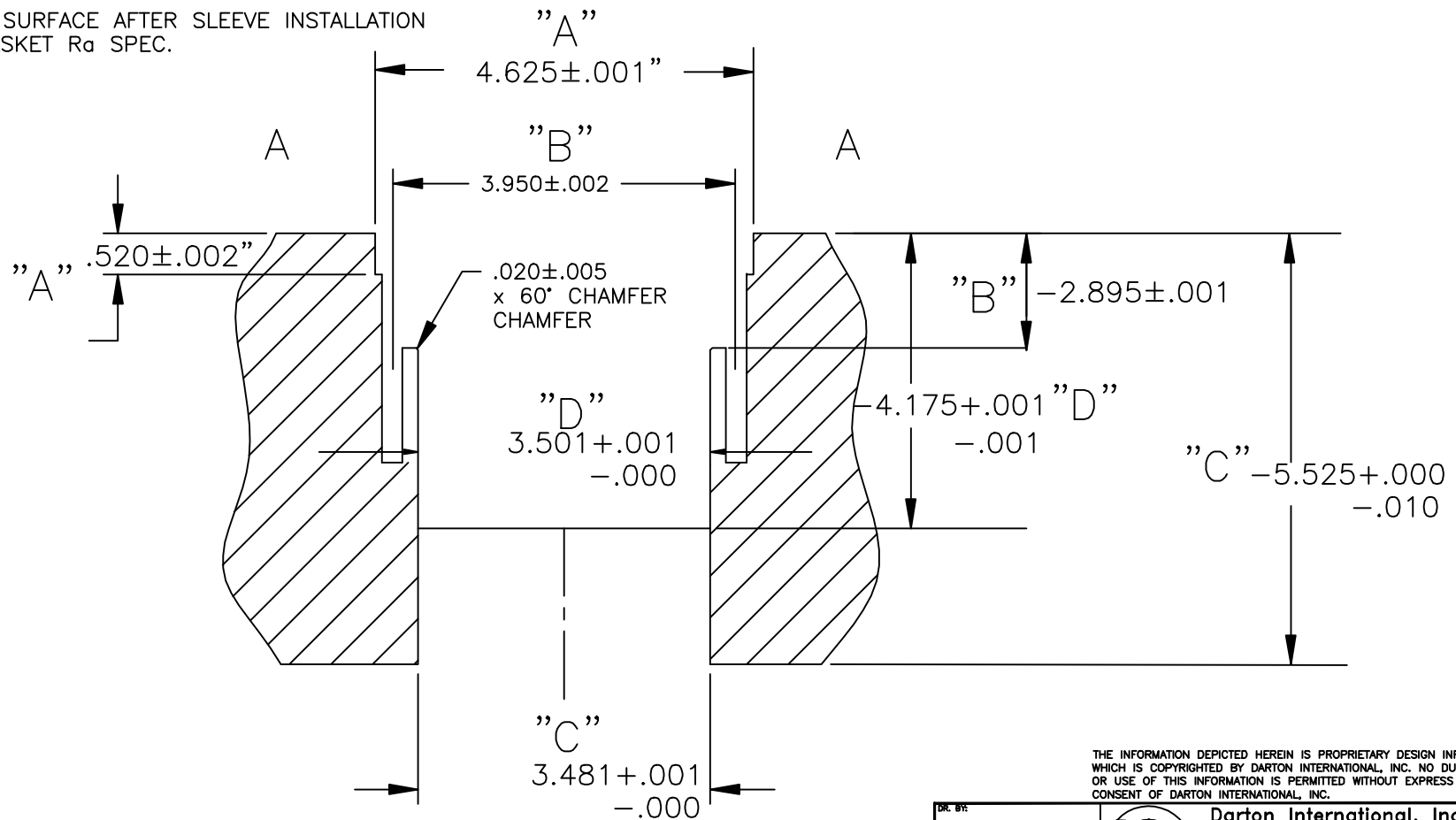

NOTE:

1. PRIOR TO BORING FOR SLEEVE INSTALLATION, BORE EXISTING SLEEVE TO FINISH BORE DIMENSION $+0.020$ " TO A DEPTH OF -5.950 FROM THE DECK SURFACE.
2. BORE CENTER - 90MM OR 3.5435"
3. DIAMETERS SHOWN ARE NOMINAL. ALWAYS MEASURE SLEEVES. CLEARANCE TO BLOCK TO BE $.001$ " TO $.0015$ "
4. DECK SURFACE AFTER SLEEVE INSTALLATION TO GASKET R_a SPEC.

REVISIONS			
REV	DESCRIPTION	DATE	APPROVAL



THE INFORMATION DEPICTED HEREIN IS PROPRIETARY DESIGN INFORMATION WHICH IS COPYRIGHTED BY DARTON INTERNATIONAL, INC. NO DUPLICATION OR USE OF THIS INFORMATION IS PERMITTED WITHOUT EXPRESS WRITTEN CONSENT OF DARTON INTERNATIONAL, INC.

DR. BY:	CAD DEPT	 Darton International, Inc. Carlsbad, CA USA (800) 713-2786 (760) 603-9895 FAX (760) 603-9629 WWW.DARTON-INTERNATIONAL.COM
DATE:	05/30/18	
CHK'D BY:		TITLE
MATERIAL:		BLOCK SPECIFICATION-DRAG honda b18 mid 84mm
HARDNESS:		SIZE
		A
		DWG. NO.
		400-145-D
		REV
		-
		SCALE
		1/2
		SHEET
		1 OF 1