

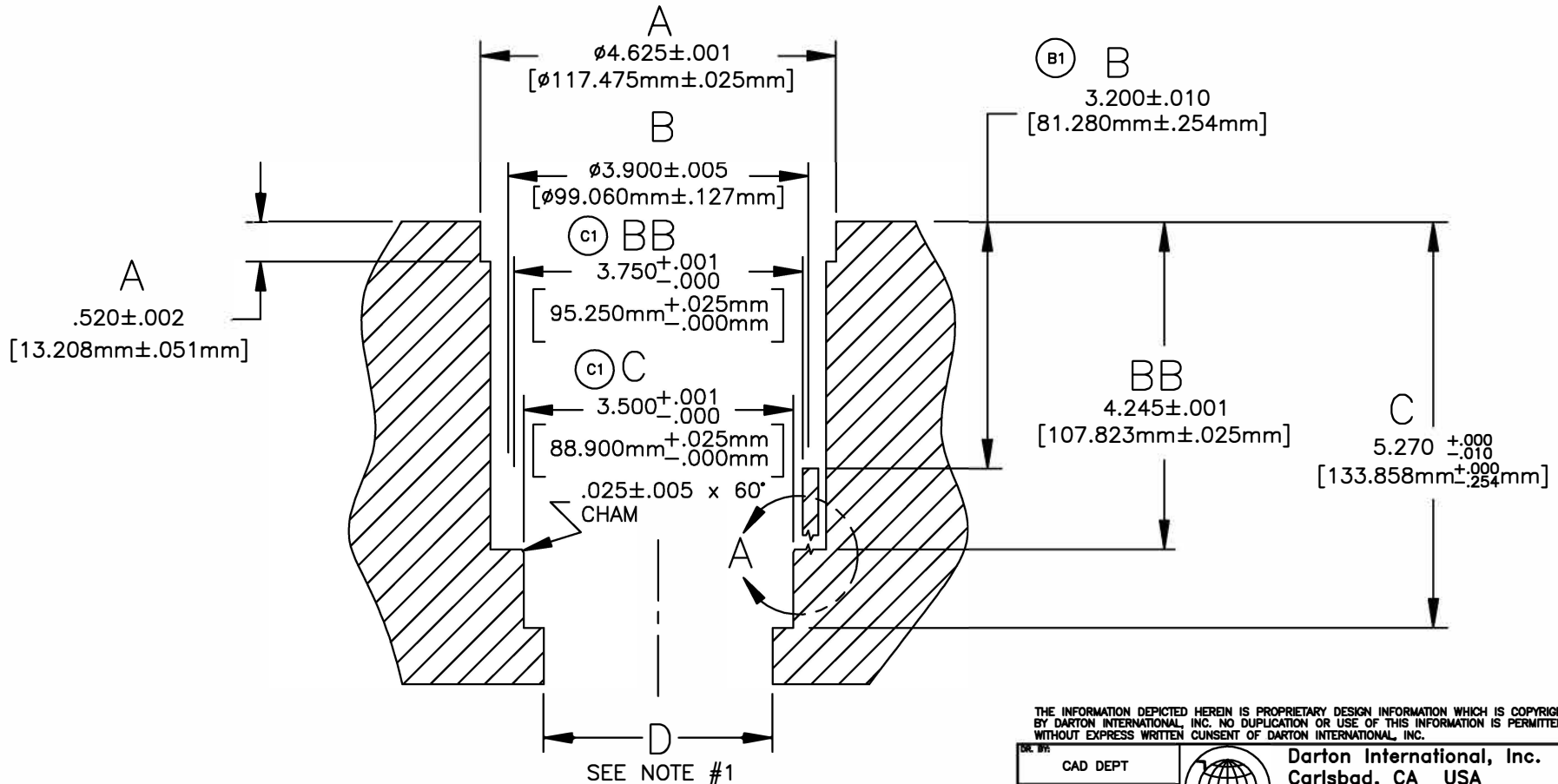

NOTE:

1. BORE THRU TO MAIN WEB AT FINISH
BORE DIA +.010
2. ON #1 CYL ONLY REMOVE REMAINING 320° ALUM WALL
DOWN TO 4.245 BY MILLING OR HAND GRINDING.
THIS WILL ELIMINATE ALL ALUM. WALL THAT WOULD
FORM A GAP BETWEEN SLEEVE AND WATER JACKET.
REFER TO PHOTO #6162 IN INSTALLATION MANUAL.

REVISIONS			
REV	DESCRIPTION	DATE	APPROVAL



THE INFORMATION DEPICTED HEREIN IS PROPRIETARY DESIGN INFORMATION WHICH IS COPYRIGHTED BY DARTON INTERNATIONAL, INC. NO DUPLICATION OR USE OF THIS INFORMATION IS PERMITTED WITHOUT EXPRESS WRITTEN CONSENT OF DARTON INTERNATIONAL, INC.

DR. BY:	CAD DEPT	 Darton International, Inc. Carlsbad, CA USA (800) 713-2786 (760) 603-9895 FAX (760) 603-9629 WWW.DARTON-INTERNATIONAL.COM		
DATE:	01/29/03			
CHKD BY:		TITLE		
MATERIAL:		BLOCK SPECIFICATION-CYL #1 HONDA M.I.D. B-16 84MM		
HARDNESS:		SIZE	DWG NO.	REV
		A	400-120-P	C
		SCALE		SHEET
		1/2		1 OF 6

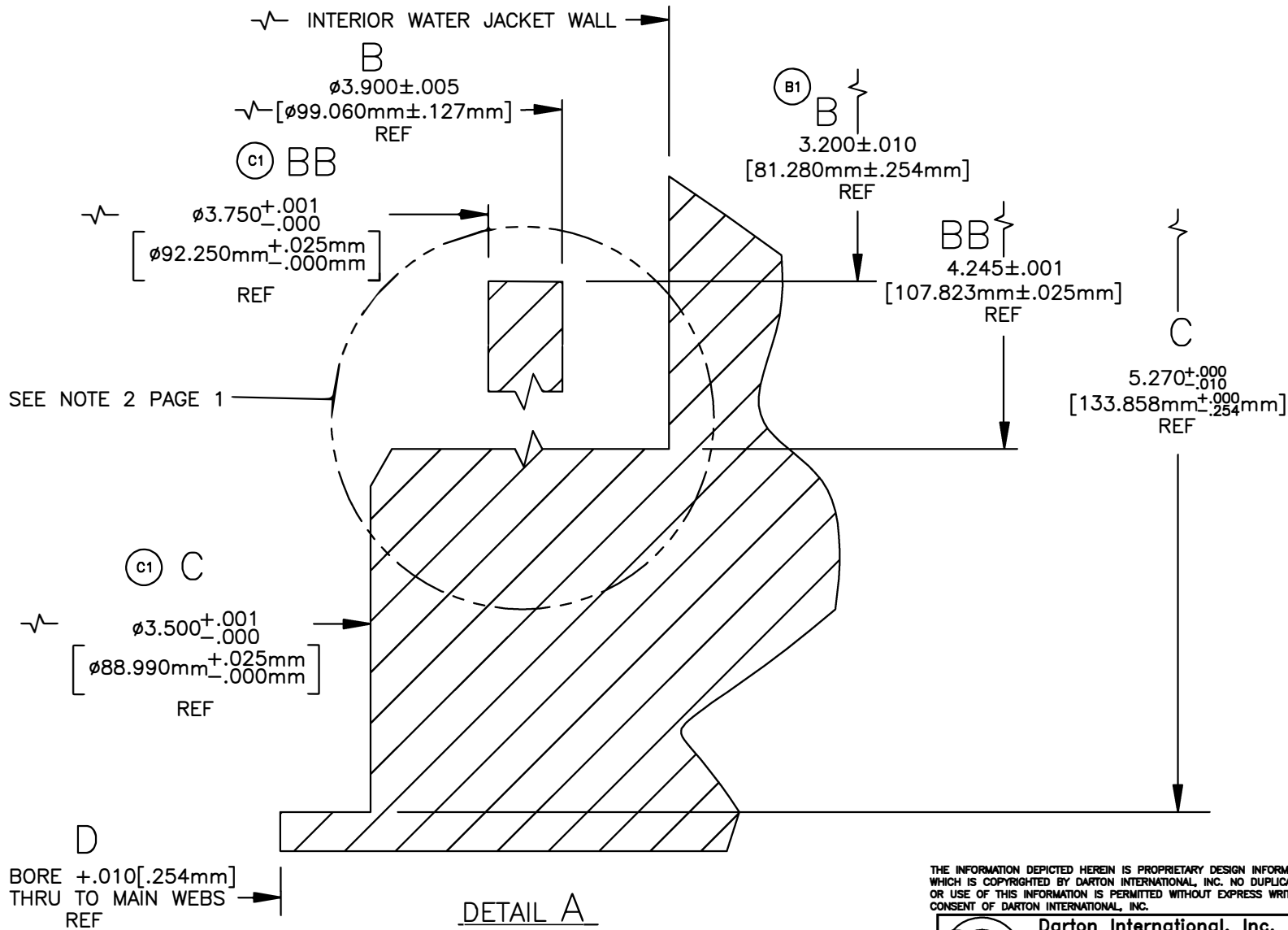

THE INFORMATION DEPICTED HEREIN IS PROPRIETARY DESIGN INFORMATION WHICH IS COPYRIGHTED BY DARTON INTERNATIONAL, INC. NO DUPLICATION OR USE OF THIS INFORMATION IS PERMITTED WITHOUT EXPRESS WRITTEN CONSENT OF DARTON INTERNATIONAL, INC.

 Darton International, Inc. Carlsbad, CA USA (800) 713-2786 (760) 603-9895 FAX (760) 603-9829 WWW.DARTON-INTERNATIONAL.COM			
			TITLE BLOCK SPECIFICATION-CYL #1 HONDA M.I.D. B-16 84mm
SIZE	400-120-P	REV	C
SCALE	1/2	SHEET 2 OF 6	

NOTE:

- BORE THRU TO MAIN WEB AT FINISH
BORE DIA +.010

REVISIONS			
REV	DESCRIPTION	DATE	APPROVAL

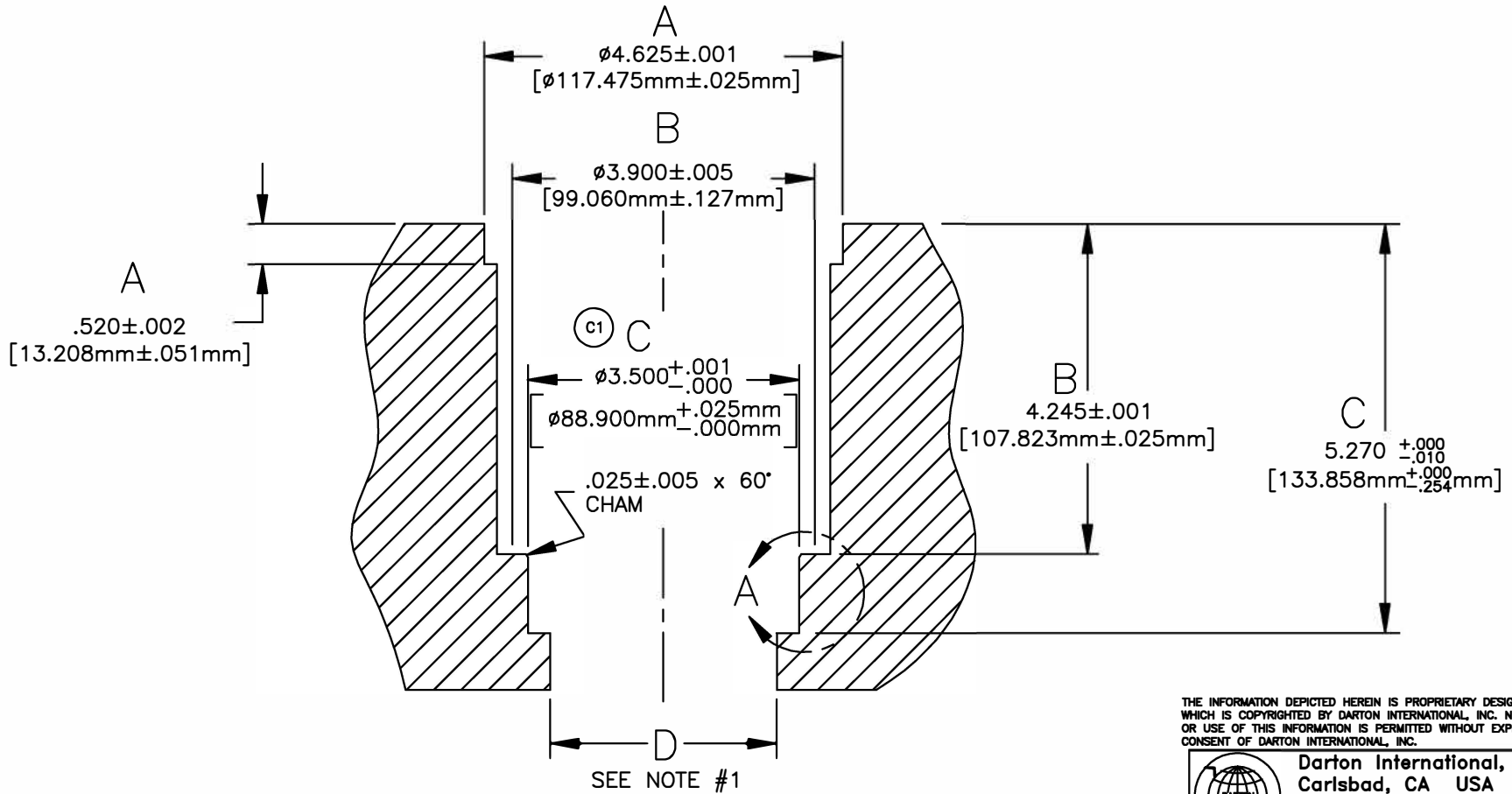

THE INFORMATION DEPICTED HEREIN IS PROPRIETARY DESIGN INFORMATION WHICH IS COPYRIGHTED BY DARTON INTERNATIONAL, INC. NO DUPLICATION OR USE OF THIS INFORMATION IS PERMITTED WITHOUT EXPRESS WRITTEN CONSENT OF DARTON INTERNATIONAL, INC.

 Darton International, Inc. Carlsbad, CA USA (800) 713-2786 (760) 603-9895 FAX (760) 603-9829 WWW.DARTON-INTERNATIONAL.COM		TITLE BLOCK SPECIFICATION-CYLS #2-3 HONDA M.I.D. B-16 84mm	
		SIZE A	400-120-P
SCALE 1/2	SHEET 3 OF 6		REV C

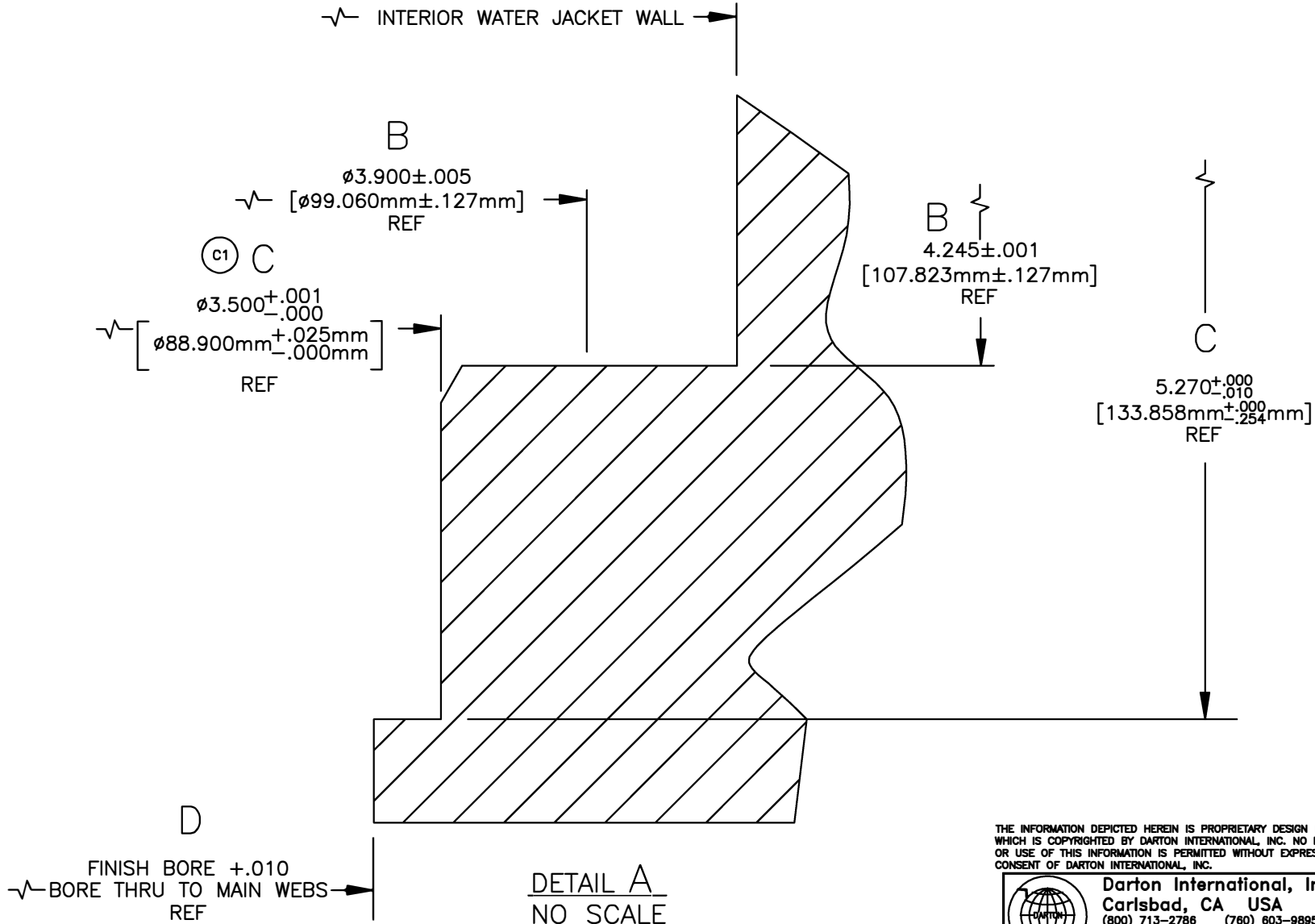

THE INFORMATION DEPICTED HEREIN IS PROPRIETARY DESIGN INFORMATION WHICH IS COPYRIGHTED BY DARTON INTERNATIONAL, INC. NO DUPLICATION OR USE OF THIS INFORMATION IS PERMITTED WITHOUT EXPRESS WRITTEN CONSENT OF DARTON INTERNATIONAL, INC.

		Darton International, Inc. Carlsbad, CA USA (800) 713-2786 (760) 603-9895 FAX (760) 603-9629 WWW.DARTON-INTERNATIONAL.COM		
		TITLE BLOCK SPECIFICATION-CYLS #2-3 HONDA M.I.D. B-16 84mm		
SIZE	A	400-120-P	REV	C
SCALE	1/2	SHEET 4 OF 6		

NOTE:

1. BORE THRU TO MAIN WEB AT FINISH
BORE DIA +.010
2. ON #4 CYL ONLY REMOVE REMAINING 280° ALUM WALL
DOWN TO 4.245 BY MILLING OR HAND GRINDING.
THIS WILL ELIMINATE ALL ALUM. WALL THAT WOULD
FORM A GAP BETWEEN SLEEVE AND WATER JACKET.
REFER TO PHOTO #6162 IN INSTALLATION MANUAL.

REVISIONS			
REV	DESCRIPTION	DATE	APPROVAL

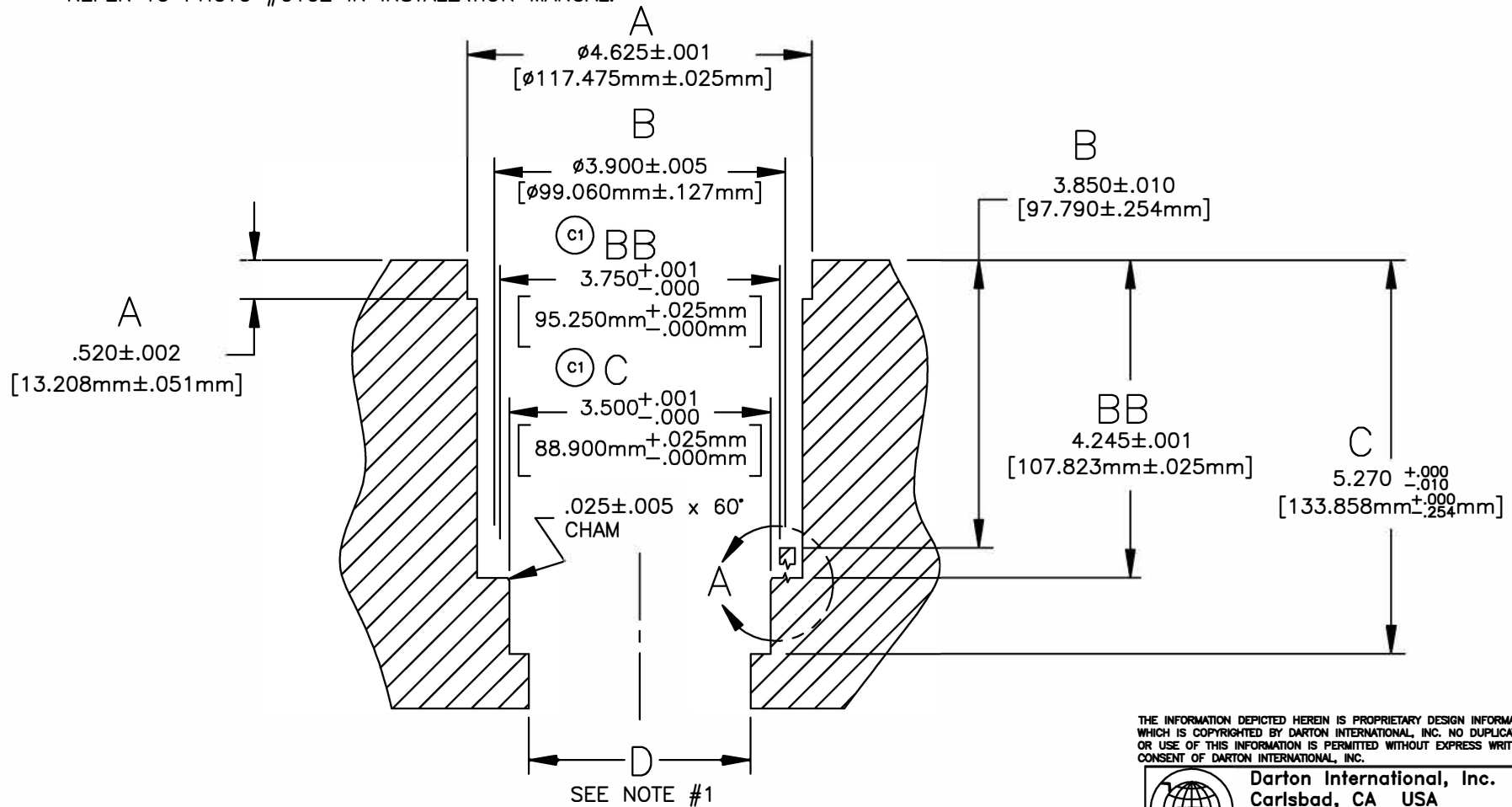

THE INFORMATION DEPICTED HEREIN IS PROPRIETARY DESIGN INFORMATION WHICH IS COPYRIGHTED BY DARTON INTERNATIONAL, INC. NO DUPLICATION OR USE OF THIS INFORMATION IS PERMITTED WITHOUT EXPRESS WRITTEN CONSENT OF DARTON INTERNATIONAL, INC.



Darton International, Inc.
 Carlsbad, CA USA
 (800) 713-2786 (760) 603-9895
 FAX (760) 603-9629
 WWW.DARTON-INTERNATIONAL.COM

TITLE		
BLOCK SPECIFICATION-CYL #4 HONDA M.I.D. B-16 84mm		
SIZE	400-120-P	REV
A		C
SCALE	1/2	SHEET 5 OF 6

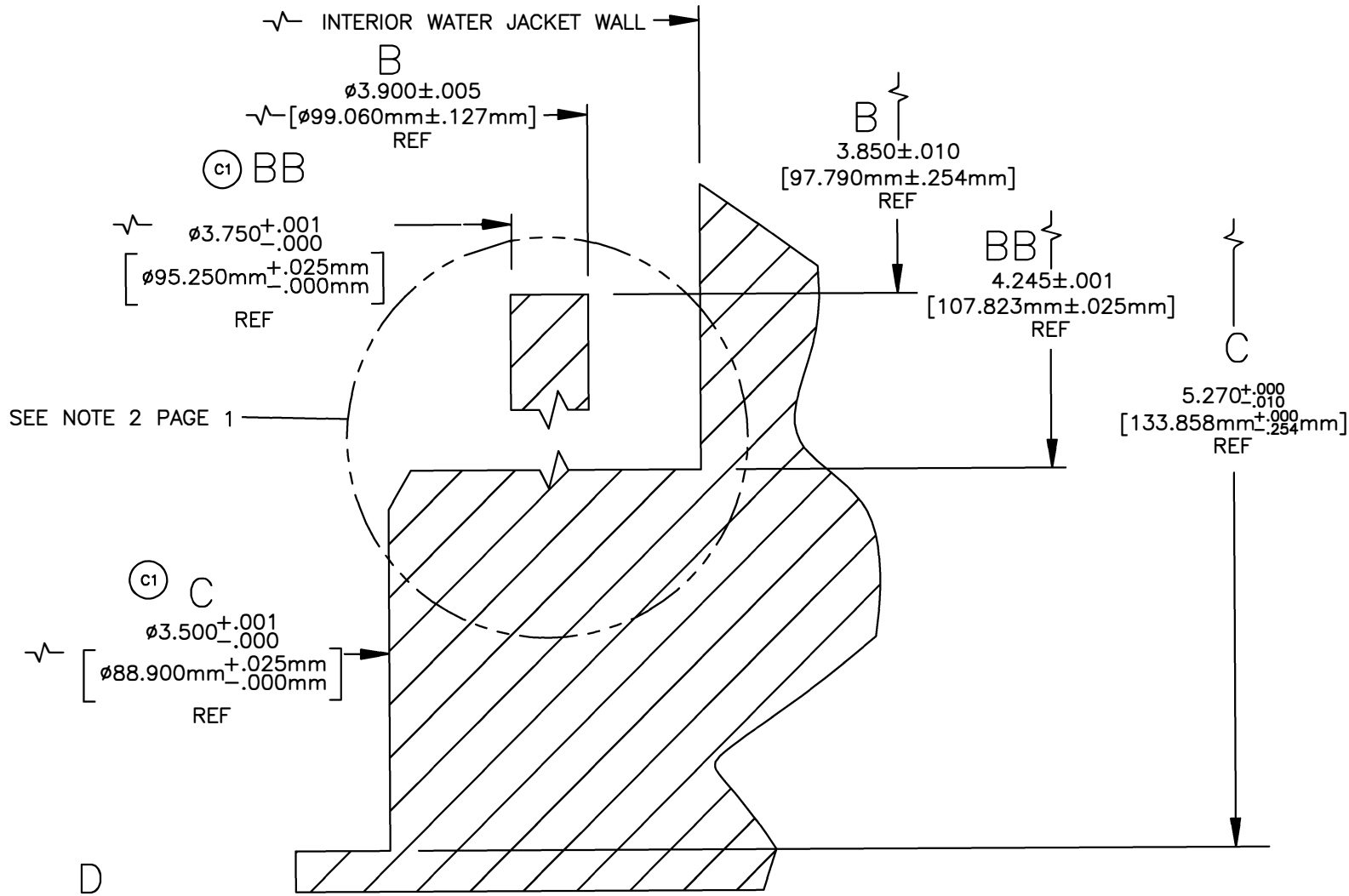

D
 FINISH BORE $+0.010$ [.254mm]
 BORE THRU TO MAIN WEBS
 REF

DETAIL A
NO SCALE

THE INFORMATION DEPICTED HEREIN IS PROPRIETARY DESIGN INFORMATION WHICH IS COPYRIGHTED BY DARTON INTERNATIONAL, INC. NO DUPLICATION OR USE OF THIS INFORMATION IS PERMITTED WITHOUT EXPRESS WRITTEN CONSENT OF DARTON INTERNATIONAL, INC.

 Darton International, Inc. Carlsbad, CA USA (800) 713-2786 (760) 603-9895 FAX (760) 603-9829 WWW.DARTON-INTERNATIONAL.COM			REV
			C
TITLE BLOCK SPECIFICATION - CYL #4 HONDA M.I.D. B-16 84mm			
SIZE	400-120-P		
SCALE	1/2	SHEET 6 OF 6	